

400GTi 500GTi
AUTOMOTIVE NEO/KEVLAR
TRANSDUCER WITH CAST FRAME
INSTALLATION GUIDE

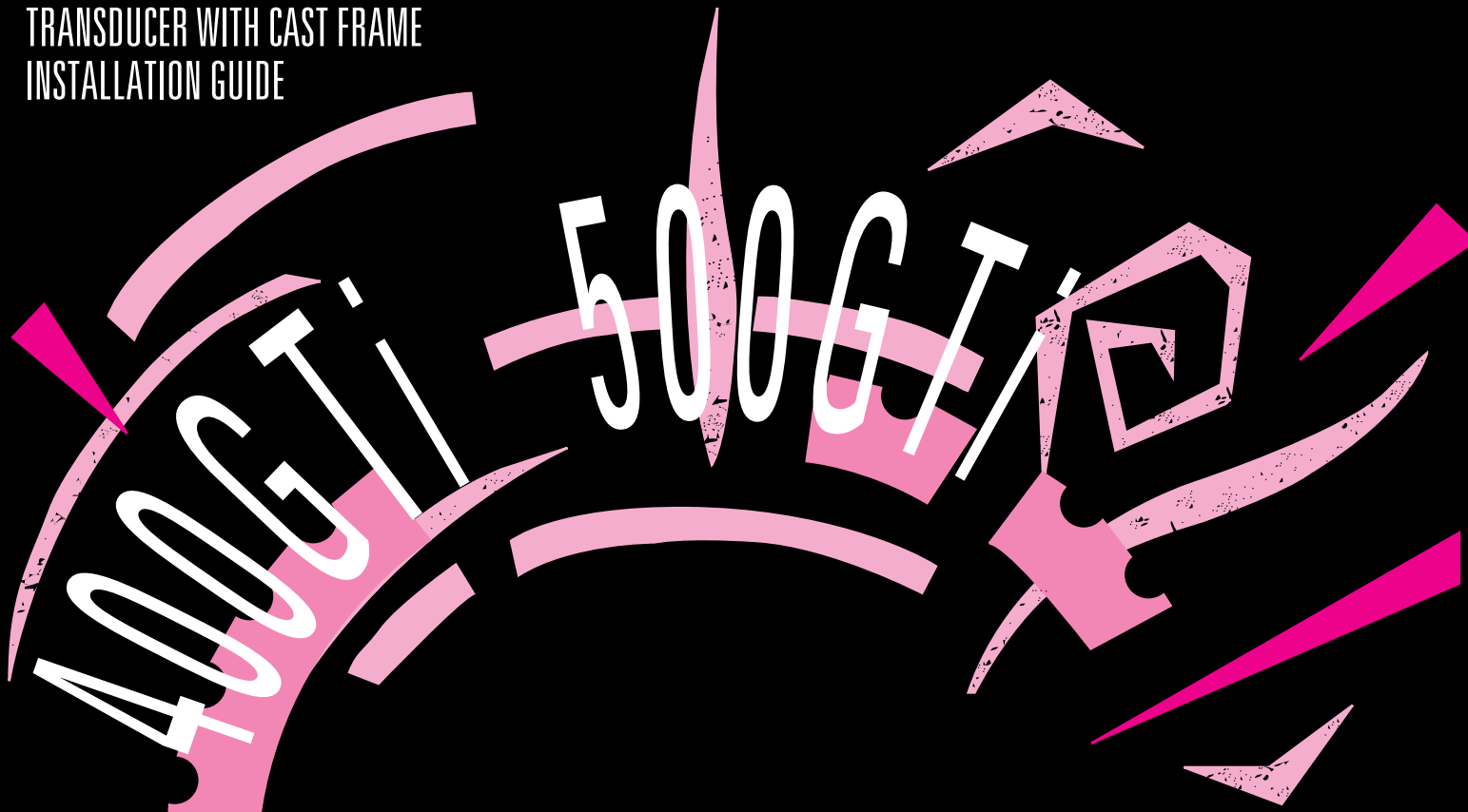
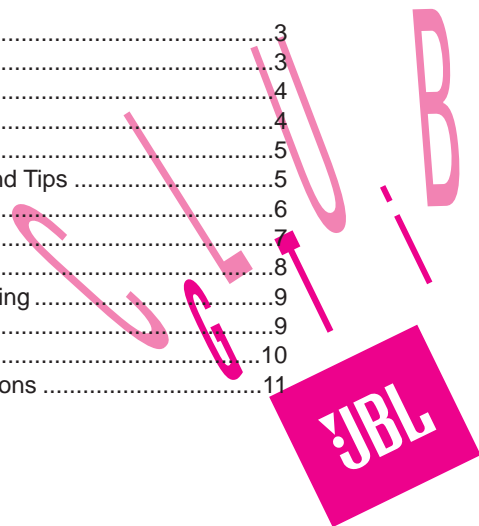

Table of Contents

Welcome to Club GTi	3
About this Manual	3
Autosound at its Best	4
Designing Your System	4
Component Placement.....	5
Installation Warnings and Tips	5
Mounting Instructions	6
Wiring	7
System Connections	8
A Note on Power Handling	9
In Case of Difficulty	9
Specifications	10
Thiele-Small Specifications	11



Welcome to Club GTi

Thank you for purchasing the finest automotive woofer/midrange JBL has ever produced. As a GTi Competition Series owner, you are a member of a select group of people who enjoy the most advanced mobile audio products available. We call this group “Club GTi.” By sending in the customer information card, which you will find attached to your warranty, we will automatically register you as a Club GTi member which will give you access to exclusive Club GTi apparel and other special offers we will make available from time to time. We suggest you fill the card out at your earliest convenience.

Also, be sure to save your sales receipt in a safe place. It will be necessary to use this document as proof of purchase in the event that you ever need warranty service. It is also useful for insurance purposes and for establishing value when you re-sell your vehicle.

About This Manual

Because of the performance capability of your GTi Competition Series product, and the variety of potential system configurations, we strongly recommend that you have the system professionally installed. You will also get a better warranty if your equipment is professionally installed by an authorized GTi dealer and you have your warranty card stamped. This manual provides information on installation and usage to help a skilled technician get the most from your GTi Competition Series product. This manual does not cover basic information about installation which is common knowledge to a professional installer, except for information which is unique to the 400 and 500GTi Midranges.

If you feel you possess the necessary skills, and prefer to install the equipment yourself, this manual will provide you with the necessary specifics to properly use the 400 or 500GTi in typical installations. Consult your JBL dealer, or a qualified technician, for more information.

Autosound at its Best

The 400 and 500GTi's are built to meet the same rigorous standards of construction and performance that have long established JBL's renowned home and professional speaker systems. The 400 and 500GTi Woofer/Midranges incorporate advanced JBL woven Kevlar cones which are especially suited to the unique acoustic and environmental conditions which characterize automotive sound. The 400 and 500GTi are engineered to provide excellent frequency response low distortion, and high-power handling, in a minimum size.

The small size of the GTi Woofer/Midranges is made possible through the use of a Neodymium magnet assembly with JBL's Stray Field Containment Geometry. By preventing stray magnetic fields, this closed circuit magnetic assembly design concentrates the magnetic field on the voice coil where it provides superior performance. This high concentration of magnetic power is coupled to a 2" Edge-wound Aluminum

Wire High Temperature Fiberglass Voice Coil. This voice coil uses lightweight aluminum wire to maintain the agility to reproduce high frequencies while its large diameter assures extremely high thermal power handling.

The cone motion of these high excursion designs is controlled by a Aromatic Polyamid Fiber Spider. This new material is able to control the 0.6" motion of the cone while maintaining musical accuracy because it is 3 times stronger than conventional spider materials.

Treated Kevlar fiber cones are used because of their combination of low weight, high stiffness and resistance to resonances. The 400 and 500GTi Woofer/Midranges are topped off with a treated fabric inverted dome for smooth reproduction of high frequencies.

What does all this technology add up to? A driver with flat frequency response, excellent off-axis response, and high output capability, all in a small and elegant package. The result is exceptionally smooth and detailed music reproduction to 5kHz and clean sound that cuts through road noise.

Designing Your System

The availability of separate components makes a variety of system designs possible. Because of their small size, the 400 and 500GTi's are perfect for many different applications. The overall quality of any system design is a result of how well all of the components work together, not just the result of the performance of any one component. JBL GTi Series tweeter and subwoofer transducers are the ideal companion products to your 400 and 500GTi Woofer/Midranges. Each of the GTi Competition Series components is designed to complement the others to provide the highest performance with the simplest and most predictable system design. To use the 400 and 500GTi as the woofer/midrange transducers in a high quality system, we recommend you use either a high quality active crossover such as JBL's GTX47, GTX4 or GTX2. If you prefer passive crossovers, we suggest a complete 408GTi or 508GTi system which includes the 08GTi Tweeter, 400 or 500GTi

Woofer/Midrange, and a laboratory-optimized crossover. The most popular system configuration is a hybrid using an active crossover for the subwoofer to midrange crossover point, and a passive crossover for the midrange to tweeter crossover. Your GTi Competition series dealer is uniquely qualified to help guide you on the best system configuration for your needs.

Component Placement

The location of each of the loudspeakers plays a vital role in achieving proper frequency response and spacious imaging. Because the 400 and 500GTi have an extremely wide and smooth dispersion pattern, excellent performance may be achieved in any vehicle. Because of the wide variety of vehicles, there is not one “right” way to locate the 400 and 500GTi, however knowledge of the following considerations will help you get the most from your system:

1. The most spacious stereo image is achieved when the 400 and 500GTi's are placed as wide apart as possible.

2. The best center image will be achieved when the distance from the left speaker to your left ear is as equal as possible to the distance from the right speaker to your right ear. This is most easily achieved by placing the 400 and 500GTi as far forward as you can.
3. The best system integration is achieved when the woofer/midrange is mounted close to the tweeter. Installing the tweeter close to the woofer/midrange helps smooth the transition from woofer/midrange to tweeter at the crossover point.
4. You will get the best frequency response when the path from the woofer/midrange and tweeter to your ear is unobstructed.
5. Because of the high acoustic energy capability of the 400 and 500GTi, they must be securely mounted in a rigid panel which is free from resonances, rattles and air leakage.

Installation Warnings and Tips

- Be careful not to cut or drill into fuel tanks, fuel lines, brake or hydraulic lines, vacuum lines or electrical wiring when working on your vehicle. Inspect behind panels before you cut or drill.
- Be sure to check for clearance of window, cranks and linkages when mounting speakers in door panels.
- Do not use the 400 and 500GTi unmounted. Failure to securely mount this product could result in damage or injury, particularly in the event of an accident.
- Do not mount the 400 and 500GTi where it will get wet.
- Always disconnect the ground wire from the battery before doing any work on the vehicle.

Mounting Instructions

Pick a mounting location after reading the recommendations in the Component Location section of this manual.

Mounting Speakers in Stock Hole Locations

1. Access the stock speaker location and remove the stock speaker. The 400 and 500GTi include mounting ring adaptors which allow the speaker to be mounted in standard 4" and 5 1/4" holes respectively.
2. Attach the mounting ring adaptor to the stock location using four #8 x 1 1/4" screws as shown in Figure A.
3. Attach the included foam gasket to the rear mounting surface of the woofer/midrange. Connect the speaker wire to the speaker by either soldering (preferred) or using crimp terminals. Make sure to observe polarity when connecting wire to the speaker. The plus terminal is indicated by the red "W" marking.
4. Mount the woofer/midrange driver to the mounting ring adaptor using three #8 x 7/16" screws and three shoulder washers as shown in Figure A.

MOUNTING RING ADAPTOR

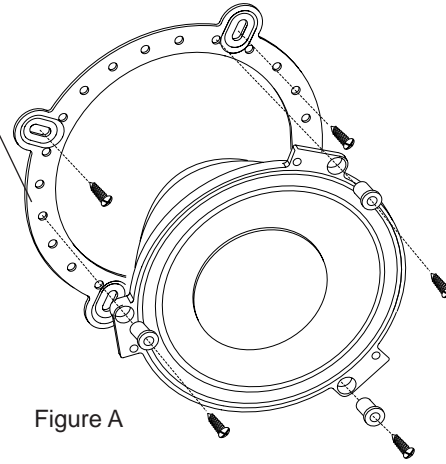

Figure A

Mounting Speakers in Custom Hole Locations

1. Using the fabric displacement ring as a template, mark the location of the 3 screw holes and the speaker cutout holes. Before cutting or drilling make sure that there are no car components, electrical wiring or any other items that could be damaged. Also choose an orientation for the

speaker which will align the grille logo in the desired orientation.

2. Cut out the speaker hole at the mounting location. Drill 3 pilot screw holes using a 1/8" (3mm) drill.
3. Run speaker wire to the hole location making sure that either an active or passive crossover is connected to the speaker.
4. Put the speaker fabric displacement ring under the speaker as shown in Figure B.
5. Attach the included foam gasket to the rear mounting surface of the woofer/midrange. Connect the speaker wire to the speaker by either soldering (preferred) or using crimp terminals. Make sure to observe polarity when connecting wire to the speaker. The plus terminal is indicated by the red "W" marking.
6. Mount the speaker to the hole location, using three #8 x 1 1/4" screws and three shoulder washers as shown in Figure B.
7. Push the grille down onto the speaker making sure the tabs match with the slots in the grille. Twist the grille about 1/2" Clockwise to lock the grille into place.

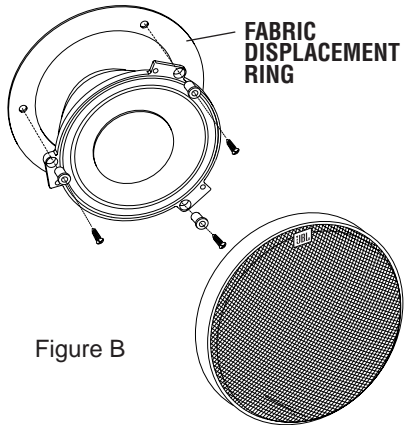

Figure B

Note: The metal grille is designed so that it can be covered with grille cloth if desired. Simply remove the metal grille from the grille frame as shown in Figure C. Then use spray adhesive to glue and wrap the grille cloth to the metal grille. Push the metal grille with cloth back in the plastic trim ring. For even better interior matching it is also possible to use plastic compatible paint to match the grille frame to the vehicle's interior.

Logo Orientation on Grille

The orientation of the logo on the grille relative to the grille frame can be adjusted. Simply remove the metal grille and reassemble the metal grille to the grille frame utilizing a different tab slot.

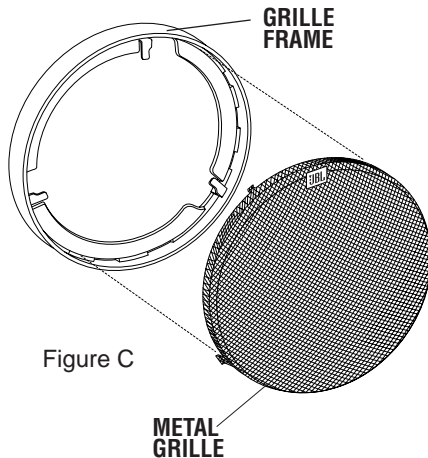

Figure C

Wiring

Use 2-conductor stranded type, insulated wire to connect the 400 and 500GTi to its crossover, and the crossover

to the amplifier. A minimum wire gauge of 18AWG is recommended, with larger size wire suggested for runs longer than 10 feet.

The polarity (the positive / negative orientation of the connections) for every speaker-to-amplifier connection must be consistent from left to right channel to assure proper imaging and optimum frequency response. This does not mean

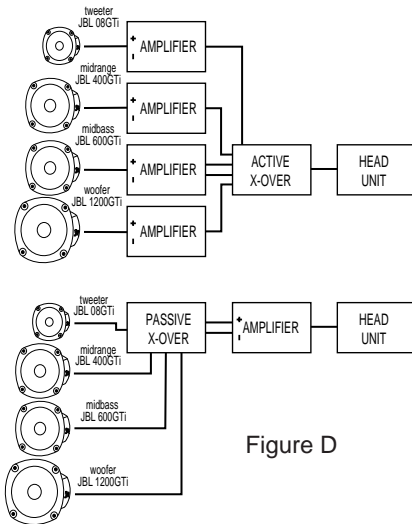

Figure D

that the 400 and 500GTi should always be connected in the same polarity as the tweeter however. It is possible, that due to the difference in the distance the sound travels from the woofer/midrange to your ears compared to the distance from the tweeters in a typical system, and the short wavelengths of sound at the crossover frequency, that a connection where the tweeters are connected in reverse polarity from the other drivers in the system may actually result in better sound. Because there is no way to accurately predict this before installation, we recommend that you try the connection both ways, and leave it in the polarity that gives the smoothest audible transition between the woofer/midrange and tweeter.

System Connections

There are a variety of system options available with the 400 and 500GTi. The simplest configuration is to use the 400 and 500GTi connected in parallel to a tweeter which includes a high-pass crossover such as the 08GTi, GT03 or GT07. Because the 400 and 500GTi is specifically designed for mid

frequency operation, it should have its high and extremely low frequencies blocked by electrical means in order to achieve the best system fidelity and the widest dynamic range.

For the best performance, we recommend that an active crossover with a minimum of 12dB per octave slope be used for the transition point between the subwoofer and the 400 or 500GTi. The optimum crossover frequency for this transition is dependent on the specific components used, the vehicle, and other installation details. As a general rule, the crossover frequency should be as low as possible to achieve the best system imaging. You can fine-tune the crossover after the installation is complete for the best sound. A good place to start your tuning process is between 50Hz and 150Hz when using the 500GTi and between 80Hz and 150Hz when using the 400GTi. In 4-way systems using a midbass driver such as the 600GTi, the crossover point may be raised higher without detrimentally affecting imaging as long as the midbass drivers can be mounted reasonably close to the midranges. This higher crossover frequency will allow the system to play louder. Since no crossover is

perfect, it is advisable to keep your crossover points away from the range where your hearing is most sensitive. Therefore we recommend that you try to keep the high-pass frequency below 250Hz and the low-pass above 2500Hz. This lets the 400 or 500GTi reproduce the entire range of frequencies, covering the most important vocal and lead instrument fundamentals without a crossover point.

If you prefer to use all passive crossovers, you will need to construct or purchase either a low-pass or band-pass filter for the midrange driver and match it to a high-pass filter for the tweeter. When a matched GTi Competition Series system is used, the best crossover choice is the laboratory-optimized, system-matched crossover which is included with the 408GTi or 508GTi system. If you have not yet installed your components, we suggest that you consult your dealer for this system package.

The most advanced system designs use active electronic crossovers such as the JBL GTX2, GTX4 or GTX47 at both the subwoofer(or midbass) to woofer/midrange transition point and at the woofer/midrange

to tweeter transition. Set the high crossover frequency at or above 5kHz if a 12dB per octave crossover is used and at or above 3.5kHz if you are using an 18 or 24dB per octave crossover. For safety, the maximum recommended amplifier power routed directly to the 400 and 500GTi Midrange is 150 watts for the 400GTi and 200 watts for the 500GTi.

A Note on Power Handling

As a result of their high efficiency, all JBL loudspeakers will produce reasonable volume levels in the automotive environment using very little amplifier power. However, the use of a low-powered amplifier to attain very high volume levels could lead to overdriving the amplifier. This will generate high distortion levels which can easily damage loudspeakers, *even if the rated power of the amplifier is below the rated maximum power handling of the loudspeaker!*

As a general rule, do not turn up the volume control past the point where you hear distortion in the form of either signal distortion from an overdriven amplifier or mechanical noise from an overstressed speaker. *For the*

best performance and system reliability, you should select an amplifier with an output rating greater than the maximum power likely to be used to generate the desired volume levels. If you want your system “Loud + Clear,” we suggest that you step up to a JBL power amplifier which has an RMS power rating equal to, but not exceeding, the *Maximum Recommended Amplifier Power* listed in the specifications of your specific JBL speaker. This margin of reserve power will ensure that the amplifier will not attempt to deliver more power than it’s design allows. Your dealer will be happy to point out which high power JBL amplifiers are optimum for your application and listening habits.

Following these guidelines will provide virtually distortion free sound reproduction and long loudspeaker life.

In Case of Difficulty

The most common difficulties are noise, distortion, and intermittent connections.

System noise is usually not the fault of the 400 and 500GTi. Hiss or “alternator whine” is most often the result of faulty grounding of the system electronics or

improper setting of amplifier level controls. An exception to this is if the passive crossover components are mounted near a source of radiated noise, the network may pick-up this noise with sufficient power to drive the 400 and 500GTi. For this reason, be careful not to mount any passive crossover components near wires carrying high currents such as battery cables or wires leading to ammeters or tachometers.

Distortion is usually the result of overdriving one or more components in the system. The problem is most likely insufficient amplifier power, or improper setting of gain controls. Refer to the instructions which came with the electronics for assistance. The 400 and 500GTi will not play as loudly, or handle the full rated power, when used without a high-pass crossover. When using the 400 or 500GTi full-range, be careful to limit the volume level to that which can be reproduced without audible distortion from the speaker.

If you want to talk to us about any problems, call JBL Customer Service at 1-800-336-4JBL (4525) between 9AM and 5PM eastern time.

Specifications:	400GTi	500GTi
Frequency Response Without Crossover:	80Hz – 5kHz	60Hz – 5kHz
Recommended Minimum High-Pass Crossover Frequency for Medium Power Operation:	80Hz	60Hz
Recommended Maximum Low-Pass Crossover Frequency:	5kHz	5kHz
Continuous Power Handling With 12dB Passive Network High Passed at Recommended Minimum Frequency:	100 Watts	150 Watts
Continuous Power Handling With 12dB Passive Network High Passed at 150–200Hz (Midrange Operation):	150 Watts	200 Watts
Continuous Power Handling With 18dB Per Octave High-PassActive Crossover at Recommended Minimum Frequency:	150 Watts	200 Watts
Power Handling When Used Without High-Pass:	75 Watts	100 Watts
Maximum Recommended Amplifier Power:	150 Watts	200 Watts
Minimum Recommended Amplifier Power:	20 Watts	20 Watts
Sensitivity (2.83 Volts / 1 Meter):	89dB	91dB
Impedance:	4 Ohms	4 Ohms
Dimensions:		
Overall Diameter (Mounting Tab to Frame Edge):	4 $\frac{3}{8}$ " (111mm)	5 $\frac{1}{8}$ " (130mm)
Height:	2 $\frac{1}{8}$ " (54mm)	2 $\frac{3}{8}$ " (60mm)
Mounting Depth:	1 $\frac{7}{8}$ " (48mm)	2 $\frac{1}{8}$ " (54mm)
Cutout Size:	3 $\frac{3}{4}$ " (95mm)	4 $\frac{3}{4}$ " (121mm)
Weight	1 lb. 7 oz. (0.66kg)	1 lb. 10 oz. (0.75kg)

Thiele-Small Specifications:	400GTi	500GTi
Free Air Resonance (Fs):	125Hz	100Hz
Electrical Damping (Qes):	0.52	0.51
Mechanical Damping (Qms):	5.17	5.14
Total Damping (Qt):	0.47	0.4
Equivalent Volume of Compliance (Vas):	0.0388 cu. ft. (1.10 liters)	0.1059 cu. ft. (3.0 liters)
Effective Cone Area (Sd):	(0.0060 m ²)	(0.0092 m ²)
Center to Peak Linear Excursion (Xmax):	0.126 inches (3.2mm)	0.126 inches (3.2mm)
Voice Coil DC Resistance (Re):	3.4 ohms	3.4 ohms
Voice Coil Inductance (Le):	0.22mH @ 1kHz	0.22mH @ 1kHz
Voice Coil Diameter:	2 inches (51mm)	2 inches (51mm)
Voice Coil Length (Winding Length):	0.400 inches (10.2mm)	0.400 inches (10.2mm)
Air Gap Height:	0.200 inches (5.1mm)	0.200 inches (5.1mm)
BL Product:	6.2 T/M	6.2 T/M
Effective Moving Mass (Mm):	0.28 oz. (8.0 grams)	0.32 oz. (9.0 grams)

Note: The Thiele-Small specifications shown apply only after a break-in period of approximately 2 hours.

JBL continually strives to improve its products. New materials, production methods and other refinements may result in a change from published specifications and description. The changes will equal or exceed the original specifications, unless otherwise stated.

JBL Consumer Products, Inc.
80 Crossways Park West
Woodbury, NY 11797
8500 Balboa Blvd.
Northridge, CA 91329
1-800-336-4JBL



H A Harman International Company